

Ocean 1

Running part and guiding part of outer door
/Lauf- und Führungswagen Türe außen

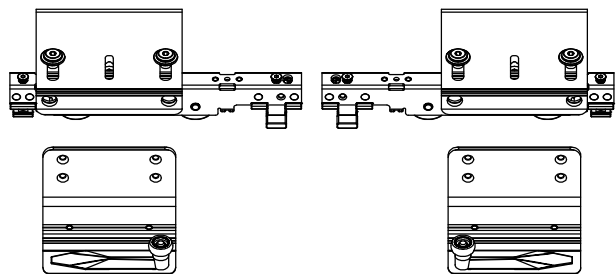

Running part and guiding part of inner door
/Lauf- und Führungswagen Türe innen

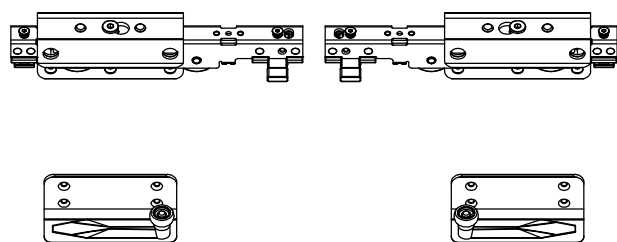

Damper
/Dämpfer

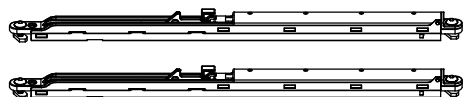

Running track
/Laufschiene



Guiding track
/Führungsschiene

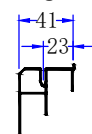

Cabinet door width calculation
/Schrank Türbreitenberechnung

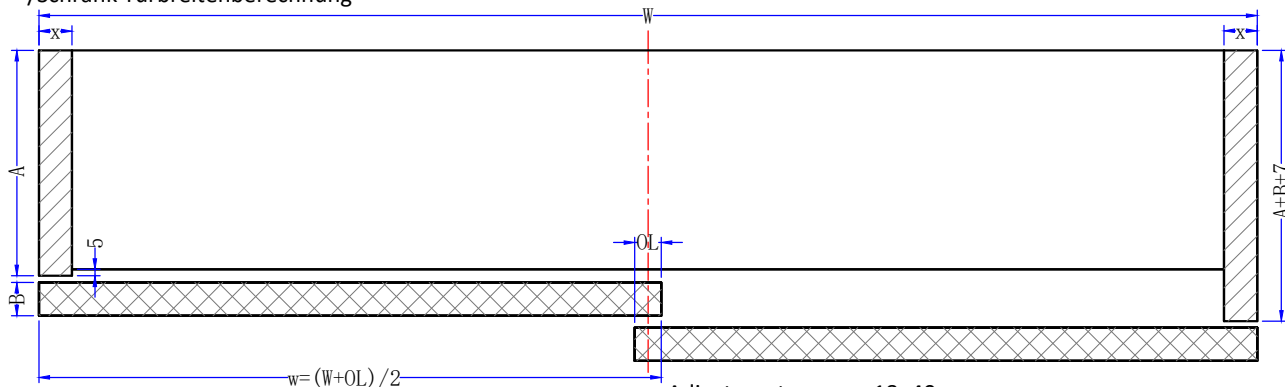

Adjustment range: 18~40mm
/Einstellung Bereich: 18-40mm

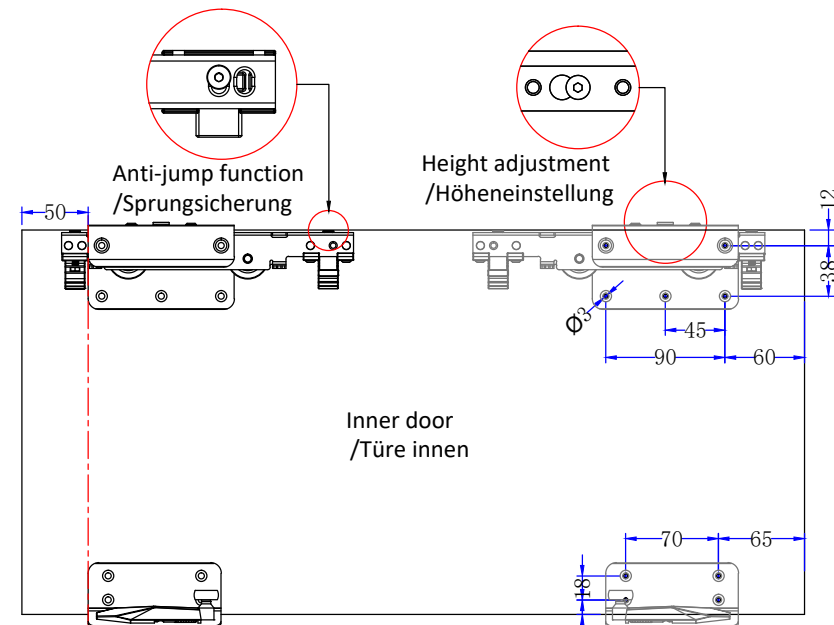
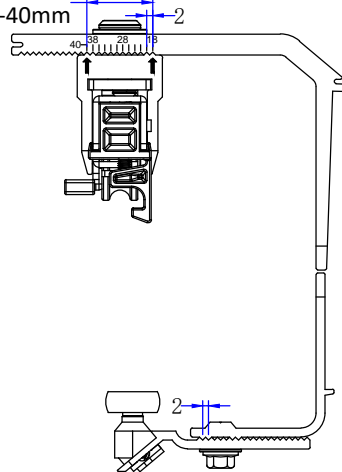
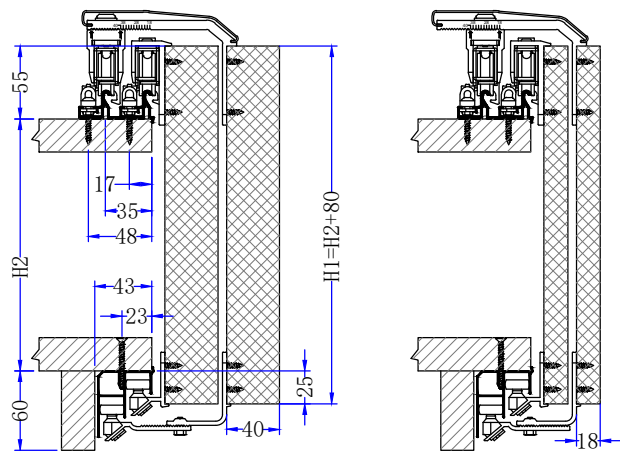

Adjustment according to door thickness
/Einstellung dicke Türen

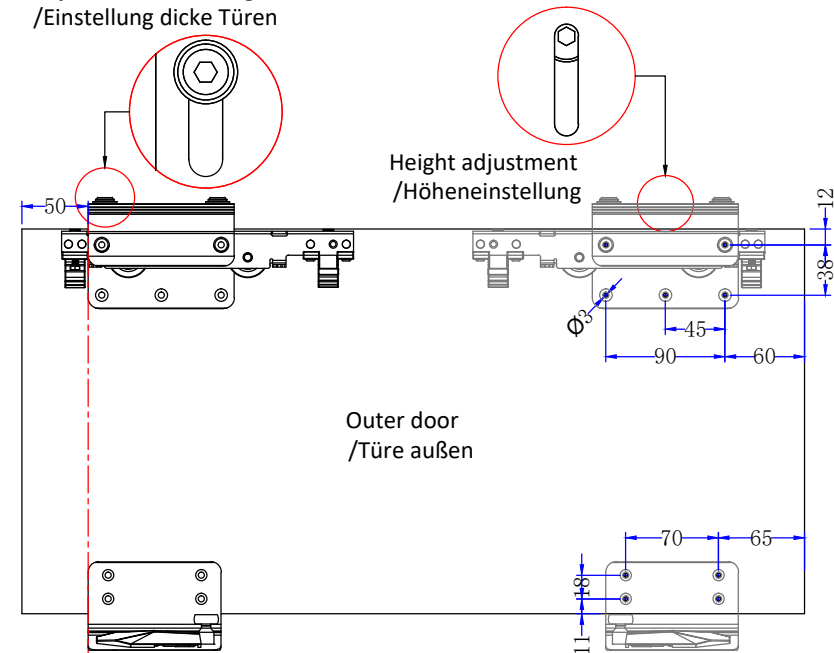

<p>OPK Europe GmbH Junghansstraße 16 72160 Horb am Neckar</p>	<p>Ocean 1</p> <p>Creator: LXJ</p>	<p>Name: Ocean 1</p>	<p>Ratio/Maßstab: 1:1</p>	<p>Format</p>
	<p>Description: Application for wooden door, framed door, Aluminum-framed door. Door panel installation height is adjustable.</p>	<p>Date/Datum: 11/05/20</p>	<p>Page / Seite: 1/1</p>	